

IMPORTANT SAFETY INSTRUCTIONS

1. READ these instructions.
2. KEEP these instructions.
3. HEED all warnings.
4. FOLLOW all instructions.
5. DO NOT use this apparatus near water.
6. CLEAN ONLY with dry cloth.
7. DO NOT block any ventilation openings. Allow sufficient distances for adequate ventilation and install in accordance with the manufacturer's instructions.
8. DO NOT install near any heat sources such as open flames, radiators, heat registers, stoves, or other apparatus (including amplifiers) that produce heat. Do not place any open flame sources on the product.
9. DO NOT defeat the safety purpose of the polarized or grounding type plug. A polarized plug has two blades with one wider than the other. A grounding type plug has two blades and a third grounding prong. The wider blade or the third prong are provided for your safety. If the provided plug does not fit into your outlet, consult an electrician for replacement of the obsolete outlet.
10. PROTECT the power cord from being walked on or pinched, particularly at plugs, convenience receptacles, and the point where they exit from the apparatus.
11. ONLY USE attachments/accessories specified by the manufacturer.
12. USE only with a cart, stand, tripod, bracket, or table specified by the manufacturer, or sold with the apparatus. When a cart is used, use caution when moving the cart/apparatus combination to avoid injury from tip-over.



13. UNPLUG this apparatus during lightning storms or when unused for long periods of time.



14. REFER all servicing to qualified service personnel. Servicing is required when the apparatus has been damaged in any way, such as power supply cord or plug is damaged, liquid has been spilled or objects have fallen into the apparatus, the apparatus has been exposed to rain or moisture, does not operate

P3RA



17. The airborne noise of the Apparatus does not exceed 70dB (A).
18. Apparatus with CLASS I construction shall be connected to a MAINS socket outlet with a protective earthing connection.
19. To reduce the risk of fire or electric shock, do not expose this apparatus to rain or moisture.
20. Do not attempt to modify this product. Doing so could result in personal injury and/or product failure.
21. Operate this product within its specified operating temperature range.

低功率電波輻射性電機管理辦法

第十二條

經型式認證合格之低功率射頻電機，非經許可，公司、商號或使用者均不得擅自變更頻率、加大功率或變更原設計之特性及功能。第十四條

低功率射頻電機之使用不得影響飛航安全及干擾合法通信；經發現有干擾現象時，應立即停用，並改善至無干擾時方得繼續使用。前項合法通信，指依電信法規定作業之無線電通信。低功率射頻電機須忍受合法通信或工業、科學及醫療用電波輻射性電機設備之干擾。

WARNING

- Battery packs may explode or release toxic materials. Risk of fire or burns. Do not open, crush, modify, disassemble, heat above 140°F (60°C), or incinerate.
- Follow instructions from manufacturer
- Only use Shure charger to recharge Shure rechargeable batteries
- WARNING: Danger of explosion if battery incorrectly replaced. Replace only with same or equivalent type.
- Never put batteries in mouth. If swallowed, contact your physician or local poison control center
- Do not short circuit; may cause burns or catch fire
- Do not charge or use battery packs other than Shure rechargeable batteries
- Dispose of battery packs properly. Check with local vendor for proper disposal of used battery packs.
- Batteries (battery pack or batteries installed) shall not be exposed to excessive heat such as sunshine, fire or the like
- Do not immerse the battery in liquid such as water, beverages, or other fluids.

- Do not attach or insert battery with polarity reversed.
- Keep away from small children.

P3RA



SAFETY PRECAUTIONS

The possible results of incorrect use are marked by one of the two symbols—"WARNING" and "CAUTION"—depending on the imminence of the danger and the severity of the damage.

	<p>WARNING: Ignoring these warnings may cause severe injury or death as a result of incorrect operation.</p>
	<p>CAUTION: Ignoring these cautions may cause moderate injury or property damage as a result of incorrect operation.</p>

CAUTION

- Never disassemble or modify the device, as failures may result.
- Do not subject to extreme force and do not pull on the cable or failures may result.
- Keep the product dry and avoid exposure to extreme temperatures and humidity.

WARNING

- If water or other foreign objects enter the inside of the device, fire or electric shock may result.
- Do not attempt to modify this product. Doing so could result in personal injury and/or product failure.

This device is able to produce sound volume higher than 85 dB SPL. Please check your maximum allowed continuous noise exposure level based on your national employment protection requirements.

WARNING

LISTENING TO AUDIO AT EXCESSIVE VOLUMES CAN CAUSE PERMANENT HEARING DAMAGE. USE AS LOW A VOLUME AS POSSIBLE. Over exposure to excessive sound levels can damage your ears resulting in permanent noise-induced hearing loss (NIHL). Please use the following guidelines established by the Occupational Safety Health Administration (OSHA) on maximum time exposure to sound pressure levels before hearing damage occurs.

<p>90 dB SPL at 8 hours</p>	<p>95 dB SPL at 4 hours</p>	<p>100 dB SPL at 2 hours</p>	<p>105 dB SPL at 1 hour</p>
--	--	---	--

110 dB SPL at ½ hour	115 dB SPL at 15 minutes	120 dB SPL Avoid or damage may occur
--------------------------------	------------------------------------	--

P3RA



This device operates under an ACMA class licence and must comply with all the conditions of that licence including operating frequencies. Before 31 December 2014, this device will comply if it is operated in the 520-820 MHz frequency band. **WARNING:** After 31 December 2014, in order to comply, this device must not be operated in the 694-820 MHz band.

GENERAL DESCRIPTION

The Shure P3RA bodypack receiver works with Shure P3T transmitters as part of the PSM300® stereo personal monitoring system. An advanced user menu featuring an LCD display delivers increased functionality over the standard PSM300 bodypack receiver, while an all-metal housing provides superior durability. Compatibility with Shure SB900-series rechargeable batteries delivers improved battery life and provides an environmentally friendly way to save money and reduce waste.

For more information on using the P3RA with the PSM300 system, refer to the PSM300 user guide (included with the transmitter and [available at shure.com](http://shure.com)).

P3RA BODYPACK

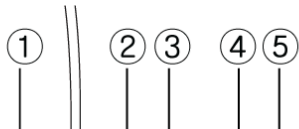

P3RA

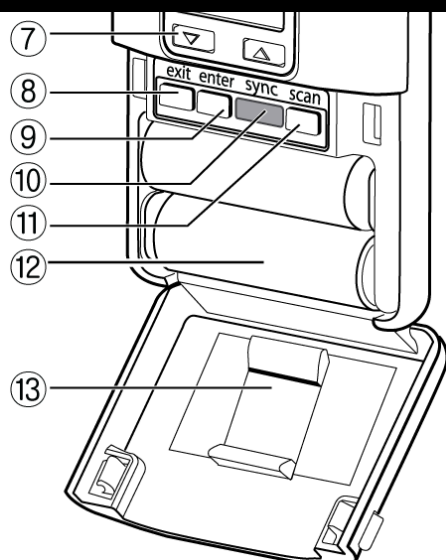

① Antenna

Receives signal from P3T transmitter

② RF Indicator

Illuminates when the bodypack is receiving a signal from the transmitter

③ Volume Knob / Power Switch

Turn to power on/off and adjust headphone volume

④ Battery LED

Indicates battery status

Note: see the battery life table for specific runtime values

⑤ Headphone Output

Use earphones or headphones with a 3.5 mm (1/8-inch) plug

⑥ Display

Shows settings and menu navigation

⑦ Navigation buttons (▲▼)

Use to scroll through menu and adjust settings

⑧ Exit button

Press to return to previous screen

⑨ Enter button

P3RA



⑩ Scan Button

Press to perform an RF scan

⑫ Battery Compartment

Uses a Shure SB900-series rechargeable battery or two AA batteries

⑬ Removable AA Adapter

Remove to use with a Shure SB900-series rechargeable battery

Note: To remove, open the door and slide the adapter out. To reinstall, press the adapter into place—there is an audible click when seated.

AUDIO SETTINGS

MODE	STEREO: Audio from channel 1 is heard on the left earphone; audio from channel 2 is on the right earphone. MIXMODE: Both channels are heard on the left and right earphones. The blend between mixes is adjustable.
EQ	Use the two-band shelving equalizer to boost either bass or treble frequencies up to +6dB in 2 dB increments. LOW BOOST: Boosts frequencies below 100 Hz HIGH BOOST: Boosts frequencies above 10 kHz OFF: No EQ (flat)
VLIMIT (Maximum Volume)	Set a value (-3 to -21 dB, adjustable in 3 dB increments) to attenuate the highest possible volume level. Turning the volume knob through its entire range of motion still affects volume; the limit simply narrows the range of dB adjustment. Note: The VLIMIT does not compress the audio.
BAL MX / BAL ST (Balance)	The behavior of the balance control depends on which mode the bodypack is set to: STEREO: Adjusts the left/right balance MIXMODE: Adjusts the blend between channel 1 and channel 2

UTILITIES

CONTRAST	Customize the display screen contrast by selecting a setting between low and high
	Locks all controls except the volume knob to prevent accidental changes to settings

P3RA



BATTERY	Displays remaining battery runtime (hours:minutes), temperature, status, cycle count, health, and voltage Note: Applies to Shure rechargeable battery only
RESTORE	Restores bodypack to factory default settings
AUTO OFF	Automatically turns off the bodypack after a selectable amount of time (5, 30, or 60 min.) while it is in power-save mode or when connected to a charger with the power on. To restore power to the bodypack, the power switch must be turned off and then on again. Note: Shure rechargeable batteries charge fastest when the bodypack is off

RF SETTINGS

The RADIO menu contains selectable GROUP and CHANNEL settings, which are used to manually synchronize the receiver with the transmitter.

The frequency and band are displayed below the group and channel settings for reference.

MIXMODE AND STEREO MONITORING

The bodypack can operate in either of the following listening modes:

STEREO (DEFAULT)

To operate in stereo mode, enter the menu and select **AUDIO > MODE > STEREO** .

In stereo mode, audio from channel 1 is heard on the left earphone, while audio from channel 2 is heard on the right earphone. Listening in stereo increases clarity and separation between the sources on each channel.

P3RA



Left (Channel 1) Right (Channel 2)

Adjusting Balance

To adjust the left/right balance, select **AUDIO > BAL ST**. Use the **▲ ▼** buttons to change the setting.

MIXMODE

To operate in MixMode, enter the menu and select **AUDIO > MODE > MIXMODE**.

In MixMode, the blend between two monitoring mixes (an instrumental mix and a vocal mix, for example) is adjustable. The signal is mono, which means each mix is heard through both the left and right earphones.

Adjusting mix blend

To adjust the blend between channel 1 and channel 2, enter the menu and select **AUDIO > BAL MX**. Use the arrow buttons (**▲ ▼**) to make adjustments.

In this scenario, an instrumental mix is on channel 1 (left) and a vocal mix is on channel 2 (right):

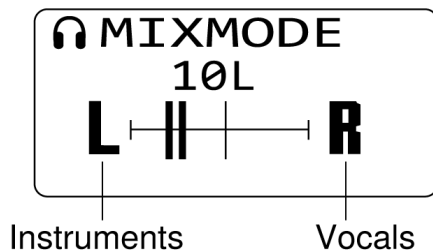

To hear more of channel one (instruments),
shift the balance towards the left.

To hear more of channel one (instruments), shift the balance towards the left.

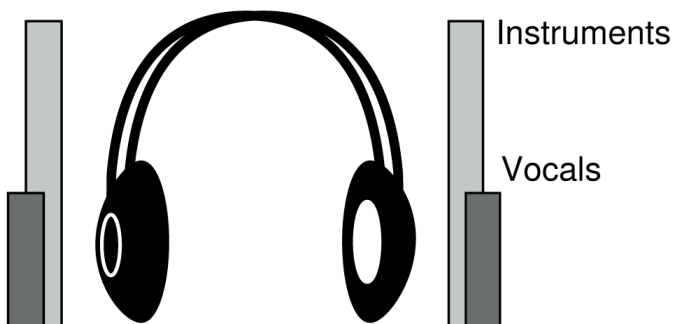



P3RA



the balance towards the right.

To hear more of channel two (vocals), shift the balance towards the right.

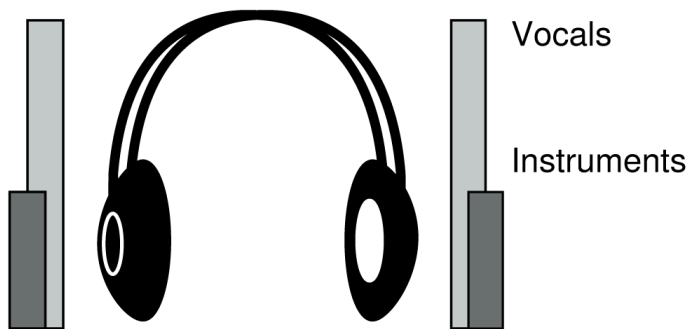

Balance and Mix Adjustments from the Home Screen

To make quick adjustments to the stereo balance or MixMode blend, use the arrow buttons (▲▼) while in the home screen. If necessary, use the lock feature to prevent any accidental adjustments.

SHURE SB900-SERIES RECHARGEABLE BATTERY

Shure SB900-series lithium-ion batteries offer a rechargeable option for powering the bodypack. Batteries quickly charge to 50% capacity in one hour and reach full charge within three hours.

Single chargers and multiple bay chargers are available to recharge the Shure batteries.

Caution: Only charge Shure rechargeable batteries with a Shure battery charger.

SINGLE BAY CHARGER

The SBC-100 single bay charger offers a compact charging solution.

1. Plug the charger into an AC power source or USB port.
2. Insert a battery into the charging bay.
3. Monitor the charging status LEDs until charging is complete.



P3RA

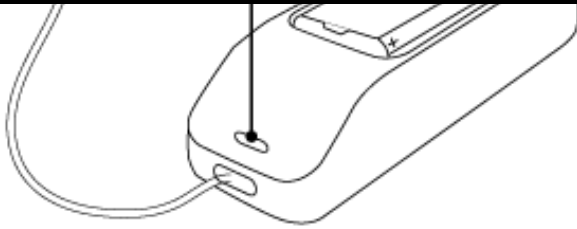

Charging Status LED

COLOR	STATUS
Red	Charging
Green	Charging Complete
Amber Flashing	Fault: check connections and battery
Off	No battery in bay

MULTIPLE BAY CHARGERS

Shure offers several models of multiple-bay chargers:

- SBC200 two-bay charger
- SBC210 two-bay charger
- SBC220 two-bay networked charger
- SBC800 eight-bay charger

SBC200 and SBC220 chargers can charge individual batteries or batteries installed in bodypacks.



1. Plug the charger into an AC power source.
2. Insert batteries or bodypacks into the charging bay.
3. Monitor the charging status LEDs until charging is complete.

Charging Status LED

COLOR	STATUS
Green	Charging Complete
Green/Red	Charge level above 90%
Red	Charging
Amber Flashing	Fault: check connections and battery
Off	No battery in bay

IMPORTANT TIPS FOR CARE AND STORAGE OF SHURE RECHARGEABLE BATTERIES

Proper care and storage of Shure batteries results in reliable performance and ensures a long lifetime.

- Always store batteries and bodypacks at room temperature
- Ideally, batteries should be charged to approximately 40% of capacity for long-term storage
- During storage, check batteries every 6 months and recharge to 40% of capacity as needed

BATTERY LIFE

Battery Indicator	Tri-Color Battery LED	Approximate Hours Remaining (h:mm)	
		Alkaline	Shure SB900C Rechargeable Battery

	Green	5:30 to 4:25	8:10 to 5:15
---	-------	--------------	--------------

P3RA



	Green	2:10 to 1:05	2:40 to 1:20
	Amber	1:05 to 0:30	1:20 to 0:35
	Red	< 0:30	< 0:35
Total Battery Life		5:30	8:10

Note: Battery life using Energizer™ brand AA Alkaline batteries and the following conditions:

- Receiver audio set to EQ = OFF, V LIMIT = OFF
- Audio output at bodypack: Pink noise at 100 dB SPL in ear with SE112 earphones (impedance at 20 Ω)

Power-save mode: When there are no earphones plugged in for 5 minutes, the receiver enters power-save mode to preserve battery life. The LED slowly fades on/off in this mode and continues to display the color that represents the remaining battery life.

SPECIFICATIONS

Audio Frequency Response

38 Hz–15 kHz

Operating Range

environment dependent

90 m (300 ft)

Active RF Sensitivity

at 20 dB SINAD

2.2 μV

Active RF Gain Control

20 dB

Adjusts RF sensitivity to provide more RF dynamic range

Image Rejection

P3RA



Intermodulation Attenuation

>50 dB

Blocking

>60 dB

Audio Output Power

1kHz @ <1% distortion, peak power, @32Ω

80 mW (driving two channels)

Output Impedance

<2.5 Ω

Minimum Load Impedance

4 Ω

Headphone Output

3.5 mm (1/8") stereo

Low Shelf

2 dB Step Size

Selectable: -6 to +6 dB @ 100 Hz

High Shelf

2 dB Step Size

Selectable: -6 to +6 dB @ 10 kHz

Volume Limiter

3 dB Step Size

Selectable: -3 to -21 dB

Net Weight

196 g(6.6 oz.) (with batteries)

Dimensions

P3RA



AA batteries	5 hours 30 minutes
SB900C	8 hours 10 minutes

Operating Temperature

-18°C to +63°C

OPTIONAL ACCESSORIES AND REPLACEMENT PARTS

Shure Lithium-Ion Rechargeable Battery.	SB900C
AA battery adapter	65A15224
Dynamic MicroDriver earphones	SE112
Dynamic MicroDriver earphones	SE215
High-definition MicroDriver earphones with tuned bass port	SE315
High-definition earphones with dual MicroDrivers	SE425
High-definition earphones with triple MicroDrivers	SE535
High-definition earphones with quad MicroDrivers	SE846
Single Rack Mount Kit	RPW503
Dual Rack Mount Kit	RPW504

CERTIFICATIONS

Meets essential requirements of the following European Directives:

- Low Voltage Directive 2014/35/EU

Conforms to the relevant requirements of regulation (EC) No.278/2009, for low voltage external power supplies.

Meets essential requirements of the following European Directives:

- WEEE Directive 2012/19/EU, as amended by 2008/34/EC
- RoHS Directive EU 2015/863

P3RA



in compliance with European Union requirements. The full text of the EU declaration of conformity is available at the following site: <https://www.shure.com/en-EU/support/declarations-of-conformity>.

Authorized European representative:

Shure Europe GmbH

Department: Global Compliance

Jakob-Dieffenbacher-Str. 12

75031 Eppingen, Germany

Phone: +49-7262-92 49 0

Fax: +49-7262-92 49 11 4

Email: EMEAsupport@shure.de

Approved under the Declaration of Conformity (DoC) provision of FCC Part 15.

Complies with requirements set out in RSS-GEN.

Industry Canada ICES-003 Compliance Label: CAN ICES-3 (B)/NMB-3(B)

This device contains licence-exempt transmitter(s)/receiver(s) that comply with Innovation, Science and Economic Development Canada's licence-exempt RSS(s). Operation is subject to the following two conditions:

1. This device may not cause interference.
2. This device must accept any interference, including interference that may cause undesired operation of the device.

L'émetteur/récepteur exempt de licence contenu dans le présent appareil est conforme aux CNR d'Innovation, Sciences et Développement économique Canada applicables aux appareils radio exempts de licence.

L'exploitation est autorisée aux deux conditions suivantes :

1. L'appareil ne doit pas produire de brouillage;
2. L'appareil doit accepter tout brouillage radioélectrique subi, même si le brouillage est susceptible d'en compromettre le fonctionnement.

(一) 本产品符合“微功率短距离无线电发射设备目录和技术要求”的具体条款和使用场景；

(二) 不得擅自改变使用场景或使用条件、扩大发射频率范围、加大发射功率（包括额外加装射频功率放大器），不得擅自更改发射天线；

(三) 不得对其他合法的无线电台（站）产生有害干扰，也不得提出免受有害干扰保护；

(四) 应当承受辐射射频能量的工业、科学及医疗（ISM）应用设备的干扰或其他合法的无线电台（站）

P3RA



（四）应当遵守电磁环境保护及相关行业主管部门的规定。

SHURE

Stay Connected!

Get updates about Shure news, product releases, special offers, events and more!

SIGN UP FOR OUR NEWSLETTER >

PRODUCTS



Microphones

Wireless Systems

Video Conferencing

Headphones

Earphones

In-Ear Monitoring

DSP, Routing & Mixing

Accessories

Software

See All Products



Sustainability

Partners

Cookie Policy

Change Cookie Preferences

Do Not Sell My Info (California Residents)

Candidate Privacy Policy

INSIGHTS & EVENTS



Insights

Newsroom

Events

Livestream

Spectrum

SUPPORT



Service & Repair

User Guides & Documentation

Online Tools

Product Training

Software & Firmware

Warranty



©2026 Shure Inc. All Rights Reserved.

[Privacy](#) | [Terms of Use](#) | [Legal](#)